

DSP170A

15W Active Horn Speaker



Description

DSP170A Active Horn Speaker is targeted at security and protection linkage, with simple arc design and beautiful appearance. It can be installed with adjustable bracket, easy to install or remove. With durable ABS plastics for the case, it can be used outdoors for a long time.

Features

- All-weather design, suitable for indoors and outdoors as well as different occasions;
- Equipped with installation brackets, easy to install;
- High-quality ABS plastics, high dynamic range speaker unit, more clear and bright;
- Support multiple monitoring audio and video connection;
- Stainless steel mounting brackets, corrosion-resistant, to ensure safety after installation;

Specifications

	Model	DSP170A
Acoustic Systems	Unit Driver	2.5"×1
	Sensitivity (1m, 1W)	105dB ± 2dB
	MAX. SPL	117dB ± 2dB
	Freq. Resp.	350Hz-10kHz
Amplifier System	Rated Power (RMS)	15W/8 Ω
	Freq. Resp.	180Hz-16KHz
	Distortion	≤1%
Others	SNR	≥65dB
	AUX IN Impedance	>10k Ω
	AUX IN Sensitivity	0.775V
	Power Interface	16V/2.5A
	Weight	1.9kg

Connection Diagram

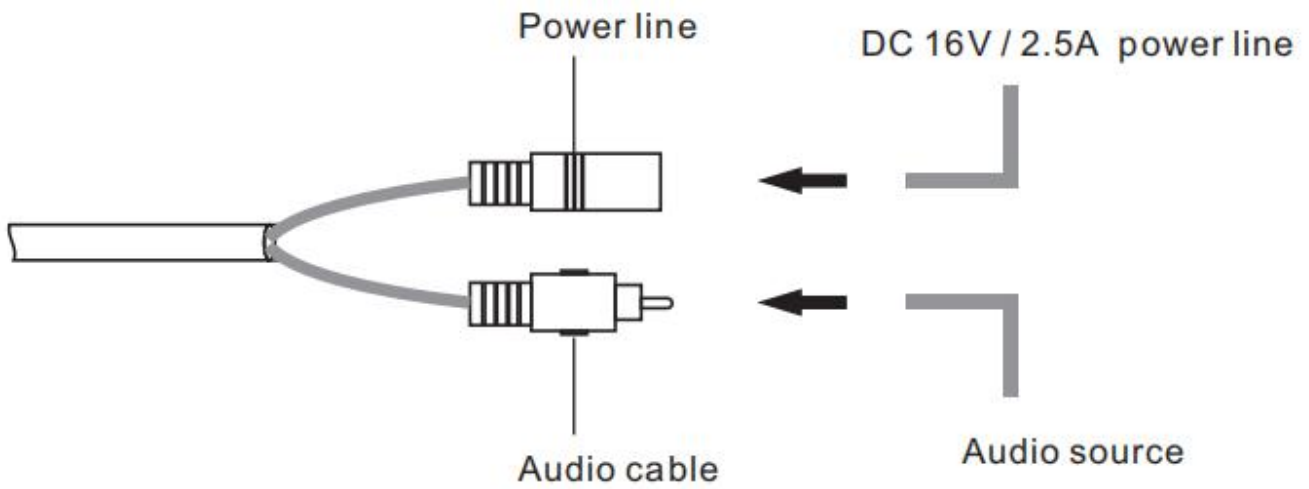

Installation

Mount screws into the mounting holes and fix it on the wall.

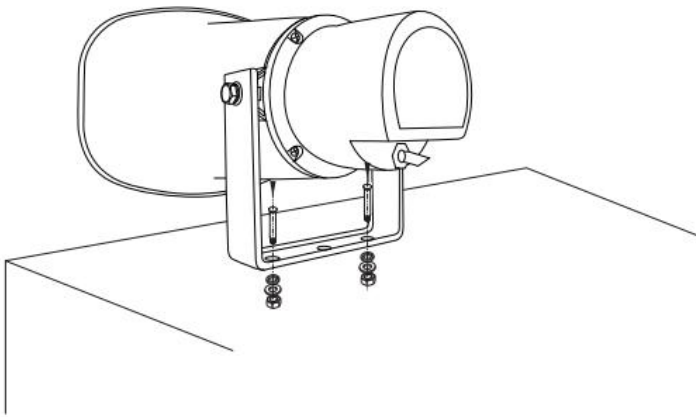

Rear View

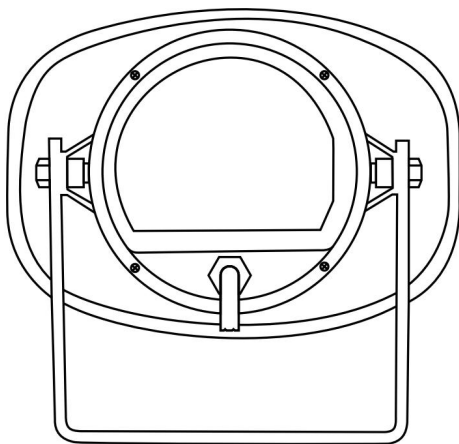

Mounting bracket view

