

MK6906 MK6920 MK6925

Professional Mixer Amplifier with EQ Control



Features

- With 4 microphone inputs that can be balanced or unbalanced, independent volume adjustment of each microphone, with mixing processing function and 7 equalization adjustment for microphone input, with phantom power supply available (+48V)
- With 3 audio (stereo) input, 2 audio output, with volume, bass, treble and equalization adjustment for audio input
- With audio source selection to select between line input and MP3. Audio from three ways and MP3 cannot be output simultaneously. Only one channel or MP3 can output once.
- Can play MP3 by USB. Can switch between two modes, select program, adjust volume, and select repeating mode and EQ mode
- With master volume adjustment
- MK6906, with rated power $2 \times 60W/8\Omega$ (when working alone, power of each channel is $60W/8\Omega$)
- MK6912, with rated power $2 \times 120W/8\Omega$ (when working alone, power of each channel is $120W/8\Omega$)
- MK6925, with rated power $2 \times 250W/8\Omega$ (when working alone, power of each channel is $250W/8\Omega$)
- With DC output protection, overload protection, short circuit protection and overheat protection
- With output level and protection indicators for two channels
- Infrared remote control of MP3

Description

MK6906/MK6920/MK6925 amplifier integrates balancing function and pre-amplifier and post amplifier. The series is equipped with three sets of stereo sound source input ports, four microphone input ports, a stereo line output ports, a recording output port and two groups of amplifier output terminals. 3-way stereo sound source channels' volume can be controlled independently cooperating with function of "choose 1 out of 4". Four mics can be controlled independently. Volumes of amplifier output are controlled together. Equipped with seven equal sections, output volume is adjustable.

Front Panel

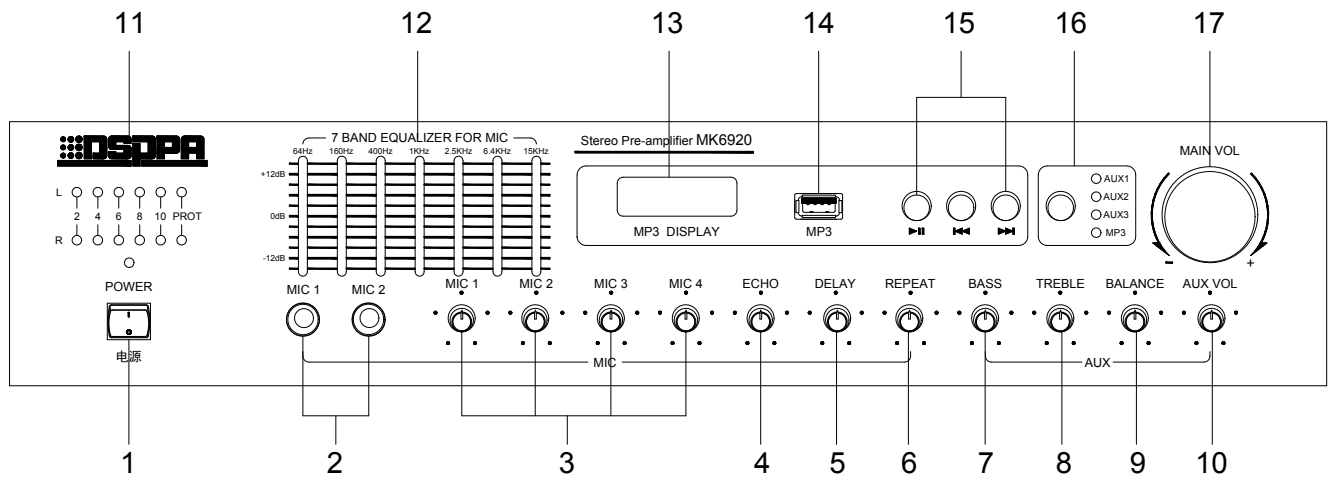

1. POWER

2. MIC1\2

Mic signal input port with independent volume control.

3. MIC volume 1\2\3\4

Each mic is with independent volume control. Turn clockwise to increase the volume and turn counterclockwise to decrease the volume.

4. ECHO

Adjust the echo volume and the ratio between echo and the direct sound to better the effect.

5. DELAY

Can control the delay time. It's the best to put switch to the middle position.

6. REPEAT

For controlling frequency of echo repeating. It's the best to put switch to the middle position.

7. BASS

Clockwise adjustment for lifting, counterclockwise adjustment for decreasing

8. TREBLE

Clockwise adjustment for lifting, counterclockwise adjustment for decreasing

9. BALANCE

Control the sound image position of the main channel and adjust the audio and video balance to its best.

10. AUX volume adjustment (master volume)

The button is for adjusting three channels' volume (channel 1/2/3). The object adjusted depends on the selected channel.

11. Output volume level indicator

If the 4th and 5th indicator is lighted, it means the output gets tip distortion. Then you should adjust the volume to turn it down and the 4th and 5th indicator will flash.

12. 12.7 segment equalization adjustment fader

Slide the fader up to raise the amplitude of the band, and slide the fader down to attenuate the amplitude of the band.

13. MP3 player

MP3 program sequence display.

14. USB port

Connect to the audio device and turn on the power. Select the MP3 channel source on the panel, insert the USB interface in the USB program USB and the machine will automatically start playing.

15. MP3 playing control buttons

Those buttons are play/pause, the previous one/the next one

16. Channel selection button and indicator

Press the button to choose a sound source (AUX1、AUX2、AUX3、MP3)to play. Indicator of selected sound source will light up.

17. Master volume control

Turn clockwise to increase the volume and turn counterclockwise to decrease the volume.

Rear Panel

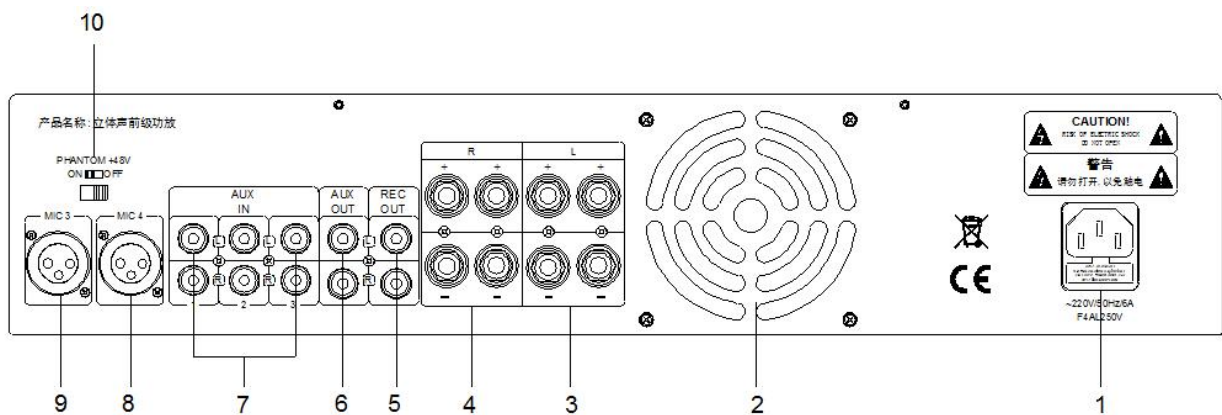

1. Power socket

Connect to~220V/50Hz/6A power. Don't plug or unplug it when it's powered on.

2. Fan window

3. Amplifier L output port: can connect to multiple speakers. Total resistance should be no less than 8Ω.

4. Amplifier R output port: can connect to multiple speakers. Total resistance should be no less than 8Ω.

5. Recording output

Can connect to peripheral equipment for audio recording.

6. Line output

For connecting to peripheral amplifier as aux line output port.

7. Audio input port

3-line audio stereo input. Can expand the local source input. Can connect to local DVD/radio. Note: Those 3-line output and MP3 can't be output together. Only one-line output or MP3 can be output.

8. MIC4 input port

9. MIC3 input port

10. +48Vphantom power switch

Turn the switch to "ON" and the +48V phantom power for the mic will be on. Turn the switch to "OFF" and the phantom power will be off.

When supporting the use of condenser microphones: When using the condenser microphone, please turn the switch "PHANTOM" to "ON" position.

When using the moving coil microphone, please turn the switch "PHANTOM" to "OFF"

Specification

Model	MK6906	MK6920	MK6925
Microphone input sensitivity	5 ± 0.5mV		4.5±0.5mV
Line input sensitivity	250 ± 50mV		
MP3 input -10dB / 1KHZ sine wave	Output 23V	Output 32V	Output 45V
Line output voltage	950 ± 150mV		
Total harmonic distortion	≤0.5 (1KHz, normal working conditions)		
Line frequency response	20-20k Hz (± 3dB)		
Microphone frequency response	80-20k Hz (± 3 dB)		
Microphone 7 balanced	64HZ: ± 12dB		
	160HZ: ± 12dB		
	400HZ: ± 12dB		
	1KHZ: ± 12dB		
	2.5KHZ: ± 12dB		
	6.4KHZ: ± 12dB		
	15KHZ: ± 12dB		
Line input and MP3 tone adjustment range bass	100Hz: ± 12dB		
Treble	10KHz: ± 12dB		
Signal to noise ratio (8Ω output)	≥75dB		
Working power supply	AC220/ 50Hz		
Phantom voltage	+ 48V		
Rated power consumption	8Ω 60W	8Ω 120W	8Ω 250W
Protective function	Overload, over temperature, short circuit		
Dimension (L × W × H)	483x 310x 88 mm		
Package dimension (L × W × H)	520mm×395mm×170mm		
Gross weight	9.5kg	10.15kg	7.6kg
Net weight	7.5kg	8.15kg	5.6kg

Specifications are subject to change without notice.